

IMPORTANT INFORMATION



Note: Please follow the below procedures. If the below procedures are not followed it may impact the life of some components and void warranties.

- Sensor taps must be installed by a qualified plumber in accordance with the Plumbing Code of Australia (PCA), AS/NZS3500 and the manufacturer's instructions.
- All pipework must be thoroughly flushed to remove any debris prior to installation as foreign materials may cause damage to internal parts and affect performance.
- If the unit is replacing an existing unit please ensure the water supply is turned off. It is recommended that isolating stop taps are fitted to the inlet connections.
- DO NOT install a mirror opposite the unit as it may reflect back causing it to falsely operate.
- Because battery consumption may vary greatly according to operating conditions, 3monkeez cannot guarantee battery life.

INSTALLATION INSTRUCTIONS

Wall Sensor Unit -

1. Sensor unit requires a 35mm dia mounting hole.
2. There is no need to remove the sensor retaining nut or the sensor.
3. Unscrew the M4 grub screw and remove the front cover cap, the O ring and the cover flange.
4. Feed both leads through the mounting hole to connect to power supply and control box.
5. Position sensor unit in hole, being careful not to damage the power leads.
6. Using appropriate screws and fixings, attach the wall mounting body to the bulkhead or wall.
7. Replace the cover flange, O ring and front cover cap. Line up the access hole in the cover flange and replace the grub screw. When all parts fit neatly, tighten the grub screw.

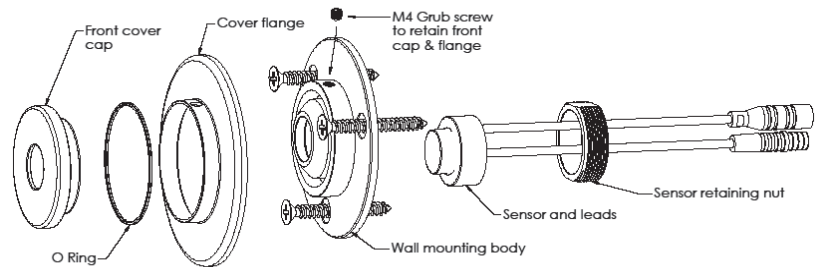

*** A set of 2 metre extension leads for the sensor is available if required. Order part # T-3MSSP-SENEXT

Solenoid Unit -

1. Locate suitable mounting point for control box. It must be within reach of the leads from the sensor unit and the flexible hose coupling to the tap body.
2. If using mains power, then a power point must be within reach of the power transformer.
3. Mark correct position, then drill and screw the mounting bracket to wall.
4. Connect the flexible hose between the tap body and the control box. Arrows on the box indicate correct direction of flow.
5. Seat the control box into the mounting bracket. Be careful not to damage the power leads.
6. Flush all pipework on inlet side to remove any debris in the line. **THIS IS IMPORTANT AS LOOSE PARTICLES CAN DESTROY THE VALVE.**
7. Check that the mesh filter is in place on the inlet side.
8. Check water pressure on inlet side. **Maximum working pressure is 500 kPa.** If necessary, install a pressure limiting valve.
9. Connect water to the inlet side.
10. Connect the power leads from the sensor unit to the control box and the power supply.
11. Turn on water supply and adjust sensor as below.

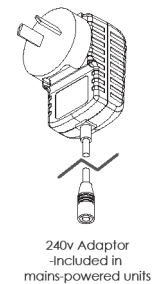
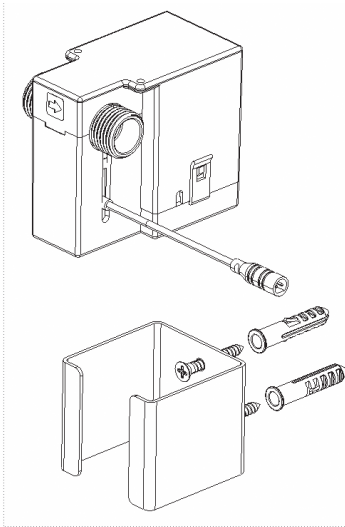

*** A mains adaptor with a 3 metre lead is available as an optional extra. Order part # T-3MSSP-HMST-3M.

SENSOR RANGE ADJUSTMENT

- To enter configuration mode, disconnect the transformer or battery pack. Wait for 60 seconds then re connect.
- The sensor tap LED will start flashing red, immediately place your hand 4-6cm away from the sensor until it is a solid red LED. Then remove your hand. You are now in configuration mode. (If your hand is not placed over the sensor immediately during this step, the sensor tap will go into normal operation mode)
- Wait for the LED to start flashing red
- Briefly place your hand 4-6cm in front of the sensor again then move your hand backwards to the distance you would like to set as the maximum range. (maximum = 200mm)
- Wait until the LED stops flashing red. The sensor distance is now set. Commence normal operation.

TO CLEAN THE FILTERS

- Switch off the water supply at the isolating stop taps.
- Remove the water connections to the control box.
- Remove the filters, inspect and remove any build up by giving a gentle shake, and rinsing under fresh tap water. If necessary use a small brush to clean. Use caution when cleaning to prevent damage.
- Re install filters. Connect the water connections pipe, turn on the water supply at the isolating stop taps. Check for any leaks.

TO REPLACE THE BATTERIES (CR123 or CR123A)

- Unplug cable and remove battery pack from control box.
- Open the cap of the battery pack by unscrewing the 2 screws using a Phillips head screwdriver.
- Remove old batteries and replace, ensuring the new batteries are installed as per the positive (+) and negative (-) markings.
- Close the battery pack and secure with the 2 screws.
- Place battery pack back in control box and plug the cable back in.

Congratulations! You have just purchased one of the premium products from 3monkeez commercial tapware range.
Proudly manufactured to Australian Standard AS/NZS3718.

SCOPE OF APPLICATION

T-3MSS-BTSWB (Battery Powered)

T-3MSS-BTSWM (Mains Powered)

INSTALLATION INSTRUCTIONS

Please Note - Optional extension barrel gives two mounting lengths - 66mm Short and 140mm Long

- Short version:**
- a) Where the Bib tap is mounted on a wall, it requires a 1/2" female BSP threaded wall connection. The tail of the wall connection must be connected to 1/2" male threaded wall connection coming out from the wall and adjacent to the control box. This allows connection to the control box using a flexible hose.
 - b) Where the Bib tap is mounted on a trough or fascia with rear access, a 1/2" female coupling is used.
- Long version:**
- a) Where the Bib tap is mounted on a wall, it requires a 1/2" male BSP threaded wall connection. The tail of the wall connection must be connected to 1/2" male threaded wall connection coming out from the wall and adjacent to the control box. This allows connection to the control box using a flexible hose.
 - b) Where the Bib tap is mounted on a trough or fascia with rear access, a 1/2" nipple and washer is normally sufficient.
1. Apply thread sealant to the thread connection of the water inlet. Ensure the opening is not covered at all by the thread sealant. *Failure to do so may restrict or block the flow of water
 2. Fit flange and screw the bib tap onto the threaded connection and tighten into place.
 3. Choose the appropriate coloured button to indicate water temperature and fix.
 4. Once the unit has been installed, connect the water supply from the control box to the bib tap. Connect leads and water supply as per instructions. Turn on water supply and test the functionality of the bib tap. Check for any leaks.

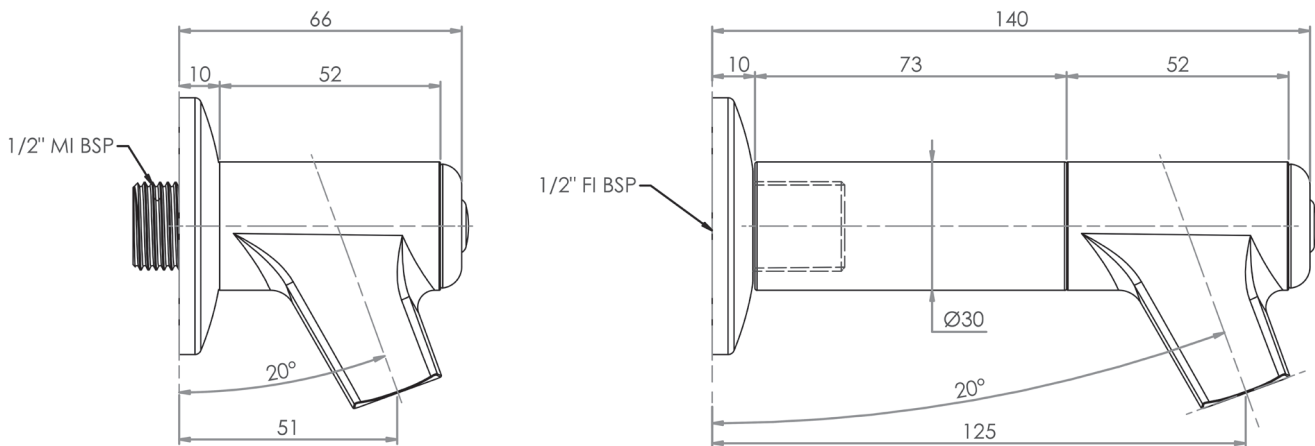

STAINLESS STEEL MAINTENANCE AND CLEANING INSTRUCTIONS

Stainless steel products must be cleaned on a regular basis to maintain the ability to resist corrosion. The surface of stainless steel has a protective layer that creates a protective shield against oxidation; which makes it durable and long lasting. Protecting this layer is important to ensure the longevity of this product.

Cleaning stainless steel products is an easy task when done regularly:

- Clear away all food and water deposits from the surface with a microfiber cloth or soft sponge; don't use abrasive materials as they have a negative impact on the protective layer
- Once cleared of debris, go over the surface with a food safe stainless steel cleaner, bicarb soda or mild detergent and water. The best chemicals for stainless steel contain alkaline and don't have chloride in them
- To remove stubborn stains, use a good quality stainless steel cleaner and non abrasive cloth
- Rinse thoroughly with clean fresh water
- Towel dry the product with a soft dry absorbent cloth after cleaning and use. This will prevent mineral deposits building up on the surface of the product
- Once dry, use a food safe stainless steel or metal polish
- Follow the grain of the metal to ensure the best results and to avoid further damage to the surface
- Always keep the product clean and dry when not in use
- Don't leave anything citric on the product as it can etch the surface over time
- Don't leave soaps and other cleaners on your stainless steel product overnight
- Don't leave damp sponges or cloths on the inside or edge of the product when not in use

TIP - Cleaning your stainless steel equipment after each use as above will ensure the product remains in good condition.