

Congratulations on your purchase of a premium commercial tapware product from 3monkeez.
Our products have been tested and are manufactured to AS 3718.

SCOPE OF APPLICATION

T-3M53500 (No Pot Filler)

Standard Height Units
T-3M53506 (6" Pot Filler)

T-3M53512 (12" Pot Filler)

IMPORTANT INFORMATION



Note: Please follow the below procedures. If the below procedures are not followed it may impact the life of some components and void warranties.

- Pre rinse unit must be installed by a qualified plumber in accordance with the Plumbing Code of Australia (PCA), AS/NZS3500 and the Manufacturer's instructions
- All pipework must be thoroughly flushed to remove any debris prior to installation as foreign materials may cause damage to internal parts and affect performance.
- If the unit is replacing an existing unit, ensure the water supply is turned off.
- Isolating stop taps must be fitted to the inlet connections in accordance with the Plumbing Code of Australia (PCA) and AS/NZS3500.

INSTALLATION INSTRUCTIONS

Step 1

Unpack the dual hob mount pre rinse unit, make sure all parts are included and no damage is present.

Step 2

Undo the nut and remove washers from the tap body. Install the pre rinse unit through 32mm-35mm hole in bench top. Maximum bench thickness is 40mm. Fit washers and nut on tap body thread and tighten.

Step 3

If pre rinse unit has a pot filler, apply grease to the pot filler spout o rings and install spout in to pot filler body, taking care to not move or damage the o rings. Tighten nut. Ensure aerator on pot filler spout is tight.

Step 4

Fit the line retractor to wall in desired position.

Step 5

Connect water to inlet hoses, ensuring temperature corresponds to handle indicators. Turn on water supply. Check for any leaks and check functionality of pre rinse unit.

TECHNICAL INFORMATION

Inlet Connections	1/2" FI BSP
Working Pressure Range	150kPa - 500kPa
Flow Rate	Trigger Valve - 4.5LPM and Pot Filler - 7.5LPM
Maximum Operating Temperature	80 Degrees Celcius
Finish	Satin Stainless Steel



CARTON CONTENTS - 1x Pre Rinse Unit, 1x Wall Bracket, 1x Pot Filler Spout (for units including pot filler), 1x Grease Tube, 1x Installation Instructions, 1x Warranty Card

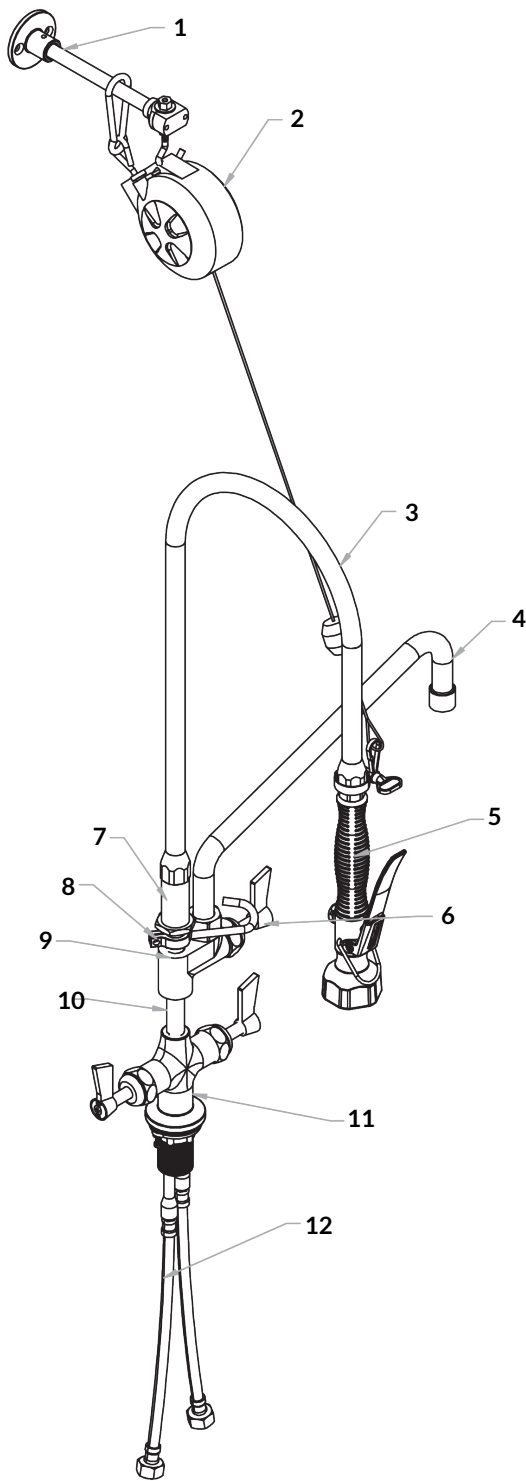

1	T-3M2902-300 - Wall bracket
2	T-3MRETRACTOR - Line retractor
3	T-3M2910 - 1000mm hose
4	T-3M3006-SO - 6" spout T-3M3012-SO - 12" spout
5	T-3M2951 - Trigger valve
6	T-3M2000-0001 - Jumper valve T-3M2000-0002 - Hot handle T-3M2000-0003 - Cold handle T-3M2000-0006 - Pot filler spindle T-3M3000 - Pot filler body
7	T-3M533814-B - Spring to riser adaptor
8	T-3M8206 - Hook
9	T-3M2927-50T - 50mm riser
10	T-3M2927-70 - 70mm riser (for below pot filler body) T-3M2927-115T - 115mm riser (units without pot filler)
11	T-3M63134 - Dual hob mount tap body T-3M2000-0001 - Jumper valve T-3M2000-0002 - Hot handle T-3M2000-0003 - Cold handle T-3M2000-0004 - Hot spindle T-3M2000-0005 - Cold spindle
12	T-3M4016 - Inlet hoses (pair)

STAINLESS STEEL MAINTENANCE AND CLEANING INSTRUCTIONS

Stainless steel products must be cleaned on a regular basis to maintain the ability to resist corrosion. The surface of stainless steel has a protective layer that creates a protective shield against oxidisation; which makes it durable and long lasting. Protecting this layer is important to ensure the longevity of this product.

Cleaning stainless steel products is an easy task when done regularly:

- Clear away all debris from the surface with a microfiber cloth or soft sponge; don't use abrasive materials.
- Once cleared of debris, go over the surface with a food safe stainless steel cleaner, bicarb soda or mild detergent and water. The best chemicals for stainless steel contain alkaline and don't have chloride in them.
- To remove stubborn stains, use a good quality stainless steel cleaner and non abrasive cloth.
- Rinse thoroughly with clean fresh water.
- Towel dry the product with a soft dry absorbent cloth after cleaning and use.
- Once dry, use a food safe stainless steel or metal polish. Follow the grain of the metal to ensure the best results and avoid damage.
- Always keep the product clean and dry when not in use.
- Don't leave anything citric on the product as it can etch the surface over time.
- Don't leave soaps and other cleaners on your stainless steel product overnight or damp sponges/cloths on of the product when not in use.

TIP - Cleaning your stainless steel equipment after each use as above will ensure the product remains in good condition.