

Congratulations! You have just purchased one of the premium products from 3monkeez cistern range.
Proudly manufactured to Australian Standards AS1172.2

IMPORTANT INFORMATION



Note: Please follow the below procedures. If the below procedures are not followed it may impact the life of some components and void warranties.

- Cistern valve must be installed by a qualified plumber in accordance with the Plumbing Code of Australia (PCA), AS/NZS3500 and the Manufacturer's instructions.
- Prior to installation, turn the water off at the mini stop, empty the cistern and soak up any residual water prior to removing the valve. After removing the valve, thoroughly clean the inside of the cistern.
- Do not use plumbers putty to seal valves or inlets.
- Operating pressure for the valve is 100- 500kpa. Where pressure exceeds 500kpa, a pressure reduction valve should be fitted.
- Do not use in-cistern toilet cleaners containing bleach or chlorine. These cause damage and failure of cistern components which may cause flooding and property damage.
- Do not remove the in-line filter from the inlet.
- This inlet valve is designed to be used with flexible couplings and is not suitable for use with solid copper pipe connections.

INSTALLATION INSTRUCTIONS

Step 1

Unpack the cistern valve, make sure all parts are included and no damage is present.

Step 2

There are 3 levels to be checked for adjustment. The critical level, the overflow level and the fill level. After removing the nut and hard washer, place the valve in the cistern, ensuring the sealing washer is on the inside of the cistern. Place hard washer on thread on outside of cistern. Screw on the nut and tighten until the sealing washer inside the cistern starts to compress. Hand tighten only. Overtightening will result in damage and may crack ceramic cisterns. Measure the difference between the top of the outlet valve overflow and the inlet valve critical level, marked CL on the inlet valve. There should be a minimum 20mm gap between the critical level and the overflow level.

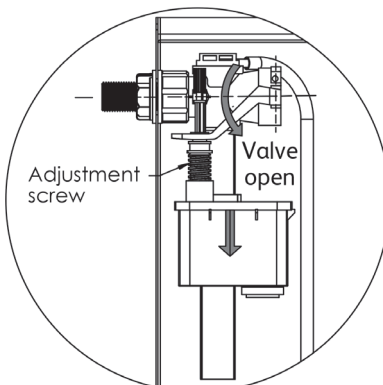
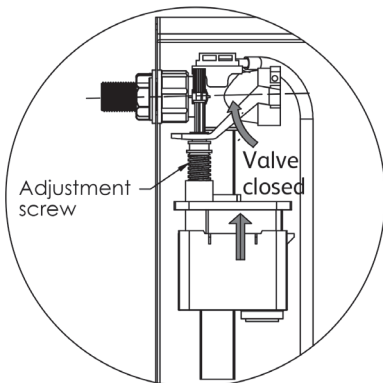
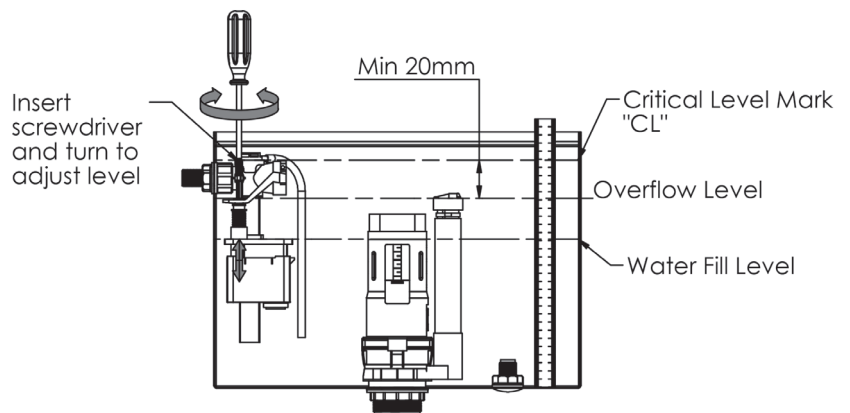

Step 3

If the gap is below 20mm, adjust the height of the outlet valve overflow.

Step 4

To adjust the water fill level, firstly ensure the float and arm move freely. Lift the arm that connects the valve to the adjustment screw and float. Adjust the height of the float to the required level by adjusting the screw with a screwdriver. Release the arm, check the float settles into the cup and the float, adjustment screw and arm move freely.

Step 5

The flexible filler hose tube should be pushed over the flow outlet and pointed down to prevent spraying upward.

Step 6

Connect the water supply and turn on. Flush test a minimum of two times to ensure the valve is filling correctly and check for any leaks. Adjust float level if necessary.

Step 7

Re-fit cistern lid.

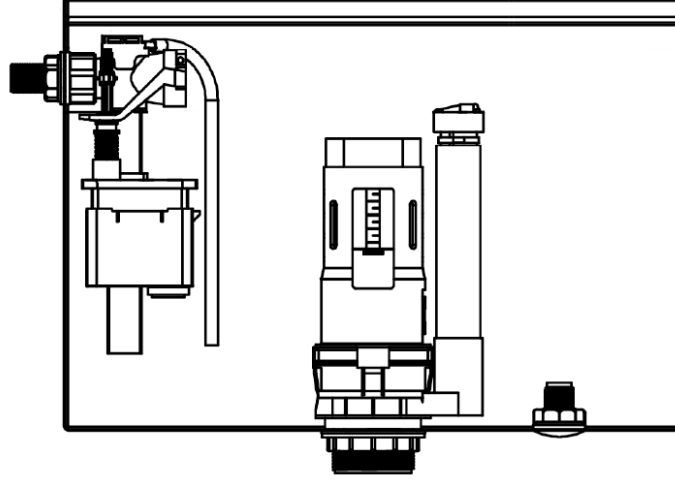

TROUBLESHOOTING

Correct pressure but slow filling or not filling	<ul style="list-style-type: none"> Check the mini stop turned on Check the flexible inlet hose for kinks or blockages Check the in-line filter inside the valve inlet pipe for debris Check the arm between the float valve adjustment screw and the valve is moving freely
Valve not shutting off	<ul style="list-style-type: none"> Check the the float level is correct and the top float level is not above the overflow Check the float, float adjustment screw and arm are all moving freely
Valve fills when cistern not used	<ul style="list-style-type: none"> Check the outlet valve. Leakage into the pan indicates the outlet valve needs repair or replacement